

Omni-polar, Hall-Effect Magnetic Position Sensor

1 Product Description

The MT3303-EN family is produced by BCD technology with both high performance and high reliability. The Hall IC internally includes an on-chip Hall voltage generator, a voltage regulator for operation with supply voltage of 2.8V to 24V, a small-signal amplifier, Hall sensors with dynamic offset cancellation, a schmitt trigger and an open-drain output with over-current protection. It features temperature compensation technique to make the magnetic switching points stable over a wide temperature range. Other key features such as reverse supply voltage protection, output over-current protection and ESD level exceeding $\pm 6\text{KV}$ (HBM) make the IC extremely robust and fault tolerant, which is important in demanding application environment such as automotive. Its extremely low operating supply voltage 2.8V also makes it possible to add external resistance in series with the supply pin for even greater protection against high voltage transients from the power supply.

When the magnetic flux density (B) is greater than the operating point (BOP), the output turns on (Low). The output is held steady till the magnetic flux density (B) is less than the releasing point (BRP), at which point it turns off (High).

2 Features

- BCD Technology
- Omni-polar Switch
- 2.8~24V Operating Vcc Range
- $-40^{\circ}\text{C} \sim 150^{\circ}\text{C}$ Operating Temperature
- Magnetic Sensitivity Option:
BOP = $\pm 150\text{Gs}$, BRP = $\pm 120\text{Gs}$
- Open-Drain Output
- -27V Reversed Power Supply Protection
- Output Limiting Current Protection
- RoHS Compliant: (EU)2015/863

3 Product Overview of MT3303-EN

| Part No. | Description |
|-------------|--|
| MT3303A-EN | Flat TO-92, bulk packaging (1000pcs/bag) |
| MT3303AT-EN | SOT-23, tape & reel (3000pcs/bag) |

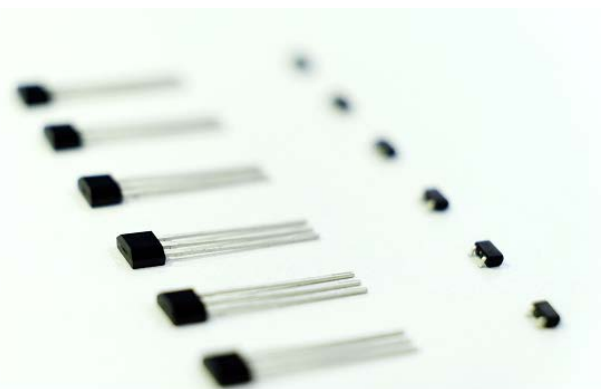

4 Applications

- Solid-state Switch
- Speed Detection
- Angular Position Detection
- Proximity Detection

5. Pin Configuration and Functions

| | Vcc | Out | GND |
|-------------|-------|----------------------|--------|
| SOT-23 | 1 | 2 | 3 |
| Flat TO-92 | 1 | 3 | 2 |
| Description | Power | Output Open-Drain | Ground |

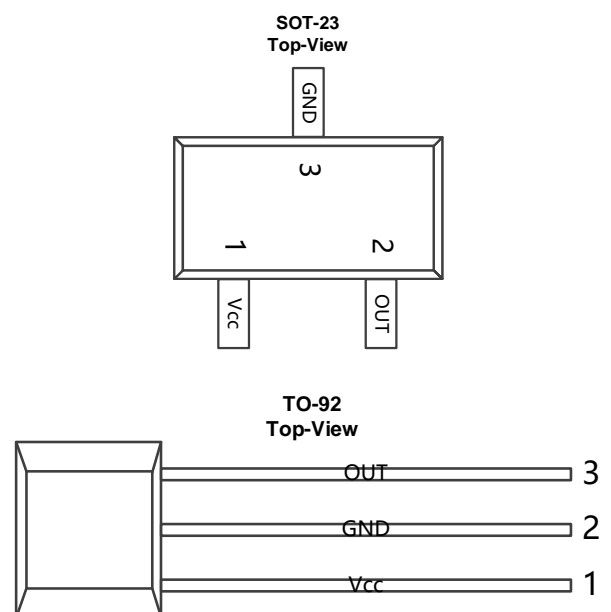

Figure.1 Pin Configuration & Functions

Table of Contents

| | | |
|----|--|----|
| 1 | Product Description..... | 1 |
| 2 | Features..... | 1 |
| 3 | Product Overview of MT3303-EN | 1 |
| 4 | Applications..... | 1 |
| 5 | Pin Configuration and Functions..... | 1 |
| 6 | Definition of Switching Function..... | 3 |
| 7 | Function Description..... | 3 |
| 8 | Feature Description..... | 3 |
| 9 | Functional Block Diagram..... | 4 |
| 10 | Electrical and Magnetic Characteristics..... | 4 |
| | 10.1 Absolute Maximum Ratings..... | 4 |
| | 10.2 Electrical Specifications..... | 5 |
| | 10.3 Magnetic Characteristics..... | 5 |
| | 10.4 ESD Ratings..... | 5 |
| | 10.5 Characteristic Performance..... | 6 |
| | 10.6 Typical Output Waveform..... | 7 |
| 11 | Typical Application Circuit..... | 7 |
| 12 | Package Material Information..... | 8 |
| | 12.1 SOT-23 Package Information..... | 8 |
| | 12.3 Flat TO-92 Package Information..... | 9 |
| 13 | Copy Rights and Disclaimer..... | 10 |

Reversion History

| | | |
|---|-------------|----------------------------|
| 1 | 4.0 Version | Update format |
| 2 | 4.1 Version | Update the Logo of MagnTek |

6 Definition of Switching Function

Figure.2 shows the device functionality and hysteresis

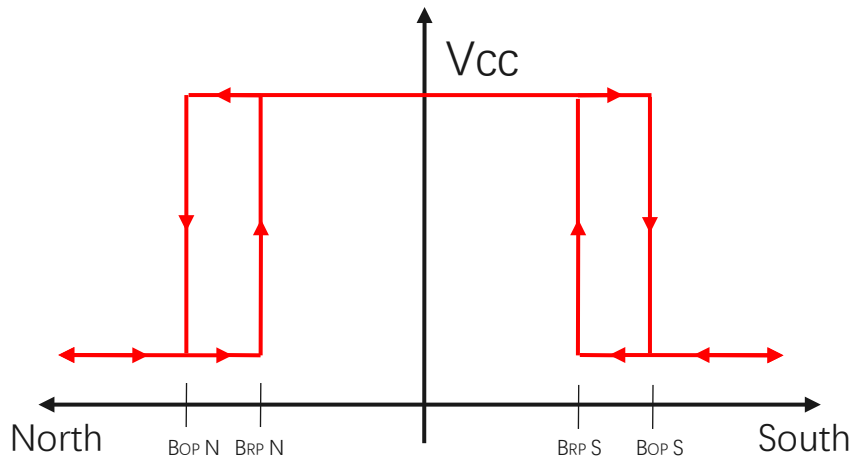

Figure.2 Omni-polar Switching Function

7 Function Description

B_{OP}: Operating Point, Magnetic flux density applied on the branded side of the package which turns the output driver ON ($V_{OUT}=Low$)

B_{RP}: Releasing Point, Magnetic flux density applied on the branded side of the package which turns the output driver OFF ($V_{OUT}=High$)

B_{HYST}: Hysteresis Window, $|B_{OP} - B_{RP}|$

Devices that have a lower magnetic threshold ($V_{OUT}=High$) detect magnets at a farther distance. Higher thresholds ($V_{OUT}=Low$) generally require a closer distance or larger magnet.

8 Feature Description

The MT3303-EN device is sensitive to the magnetic field component that is perpendicular to the top of the package

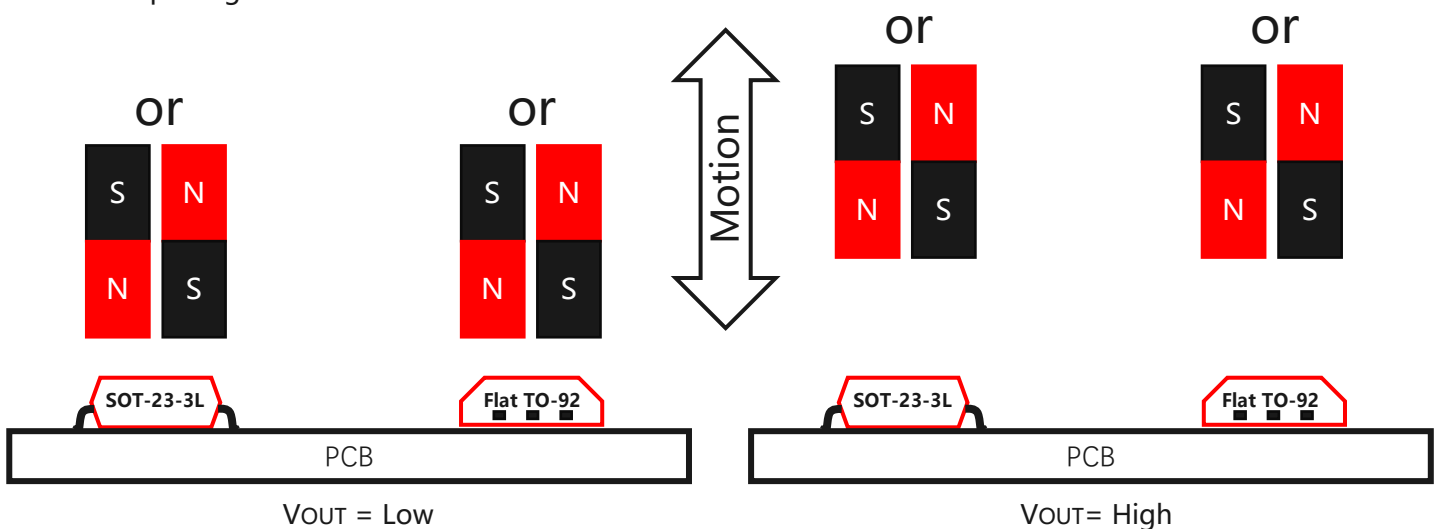

Figure.3 Flux Direction Polarity

9 Functional Block Diagram

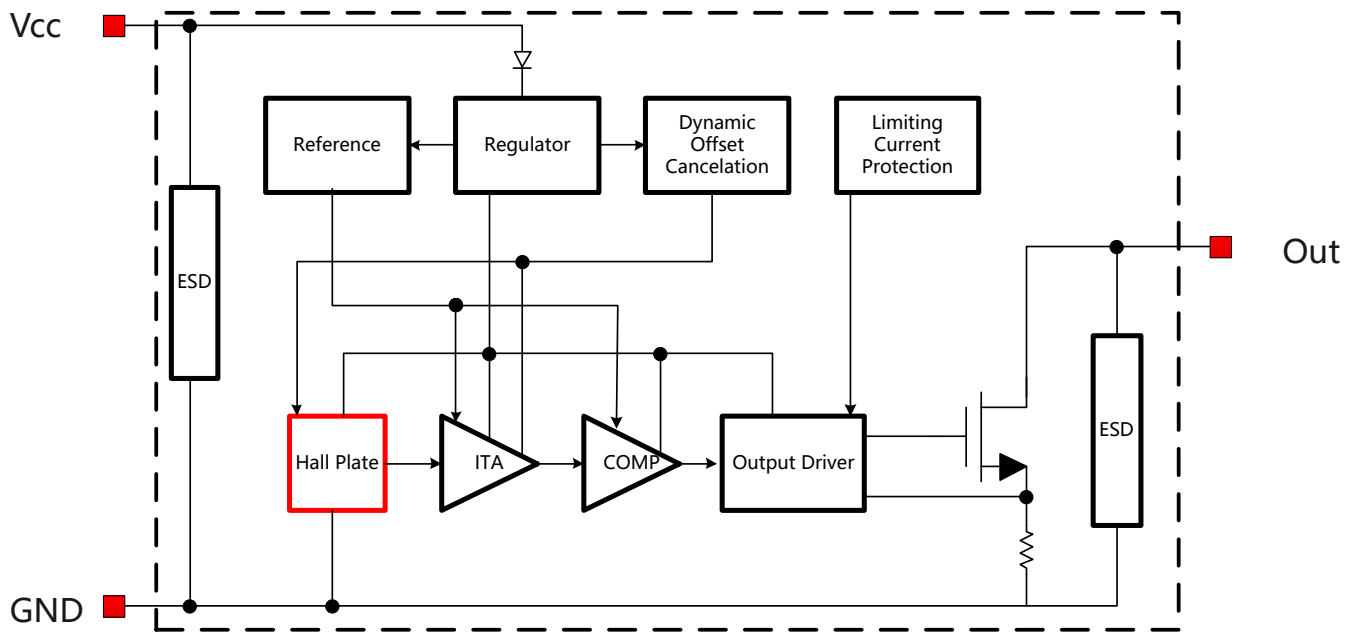

Figure.4 Functional Block Diagram

10 Electrical and Magnetic Characteristics

10.1 Absolute Maximum Ratings

Absolute maximum ratings are limited values to be applied individually, and beyond which the serviceability of the circuit may be impaired. Functional operability is not necessarily implied. Exposure to absolute maximum rating conditions for an extended period of time may affect device reliability.

| Symbol | Parameters | Min | Max | Units |
|--------|-------------------------------|----------|-----|-------|
| VCC | Supply Voltage | - | 27 | V |
| VRCC | Reverse Battery Voltage | -27 | - | V |
| VOUT | Output Voltage | - | 27 | V |
| IOUT | Continuous Output Current | - | 50 | mA |
| TA | Operating Ambient Temperature | -40 | 150 | °C |
| TS | Storage Temperature | -50 | 150 | °C |
| TJ | Junction Temperature | - | 165 | °C |
| B | Magnetic Flux Density | No Limit | | Gs |

10.2 Electrical Specifications

At $T_A = -40 \sim 150 \text{ }^\circ\text{C}$, $V_{CC} = 2.8\text{V} \sim 24\text{V}$ (unless otherwise specified)

| Symbol | Parameters | Test Condition | Min | Typ | Max | Unit |
|-------------------|---|---|-----|-----|-----|------|
| V _{CC} | Supply Voltage | Operating | 2.8 | - | 24 | V |
| I _{CC} | Supply Current | $B < B_{RP}$ | 1 | 2.3 | 3.5 | mA |
| I _{OC} | Short Circuit Protection Current | $B > B_{OP}$, $V_{OUT} = V_{CC}$ | - | 50 | - | mA |
| V _{DSON} | Output Saturation Voltage | $I_{OUT} = 20\text{mA}$, $B > B_{OP}$ | - | - | 0.4 | V |
| I _{OFF} | Output Leakage Current | $V_{OUT} = 24\text{V}$ | - | - | 10 | uA |
| T _R | Output Rise Time | $R_L = 1\text{K}\Omega$, $C_L = 20\text{pF}$ | - | - | 1.0 | us |
| T _F | Output Fall Time | $R_L = 1\text{K}\Omega$, $C_L = 20\text{pF}$ | - | - | 1.0 | us |
| T _{PO} | Power on Time | $dV_{CC}/dt > 5\text{V}/\mu\text{s}$ $B > B_{OP(MAX)}$ | - | - | 10 | us |
| F _C | Chopping Frequency | | - | 800 | - | KHz |
| F _S | Sampling Frequency | | - | 400 | - | KHz |
| R _{TH} | Thermal Resistance of SOT-23 | | - | 301 | - | °C/W |
| | Thermal Resistance of SOT-23 (Thin Outline) | | - | 301 | - | °C/W |
| | Thermal Resistance of SOT-89B | | - | 230 | - | °C/W |
| | Thermal Resistance of TO-92 | | - | 230 | - | °C/W |

10.3 Magnetic Characteristics

At $V_{CC} = 2.8\text{V} \sim 24\text{V}$ (unless otherwise specified)

| Part No. | Symbol | Min | Typ | Max | Unit |
|------------------|--|-----|------|------|------|
| MT3303-EN Series | B _{OP} , $T_A = 25^\circ\text{C}$ | ±90 | ±150 | ±190 | Gs |
| | B _{RP} , $T_A = 25^\circ\text{C}$ | ±70 | ±120 | ±160 | Gs |
| | B _{HYST} , $T_A = 25^\circ\text{C}$ | 10 | 30 | 50 | Gs |

10.4 ESD Ratings

| Symbol | Reference | Values | Unit | |
|------------------|----------------------------|--------------|-------|---|
| V _{ESD} | Human-body model (HBM) | AEC-Q100-002 | ±6000 | V |
| | Charged-device model (CDM) | AEC-Q100-011 | ±1000 | V |

10.5 Characteristic Performance

At V_{CC}=5V

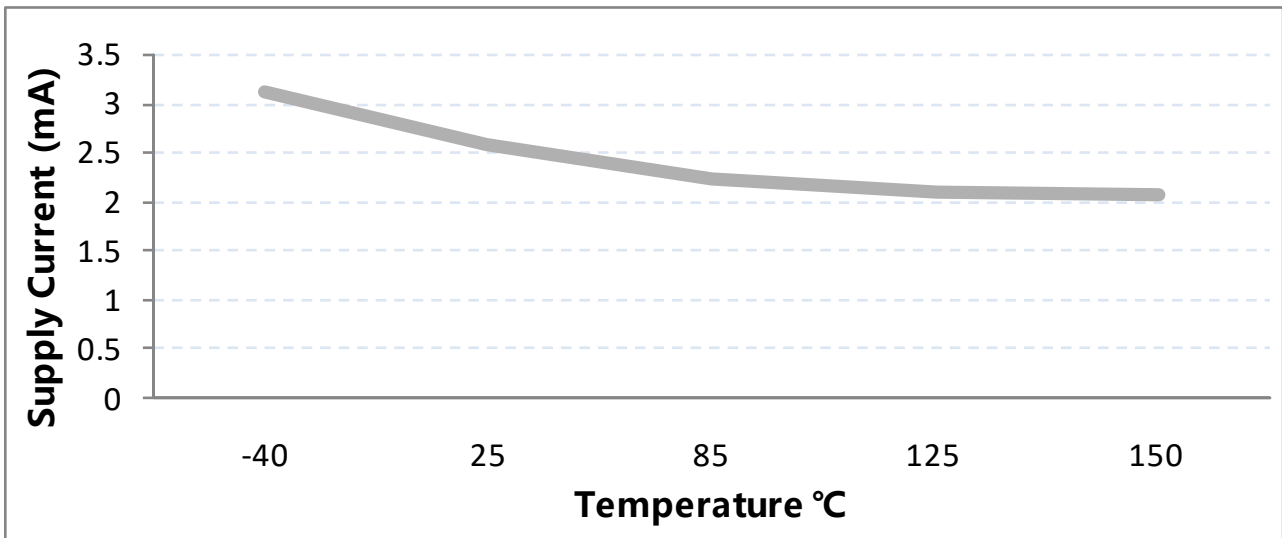

Figure.5 Supply Current vs. Temperature

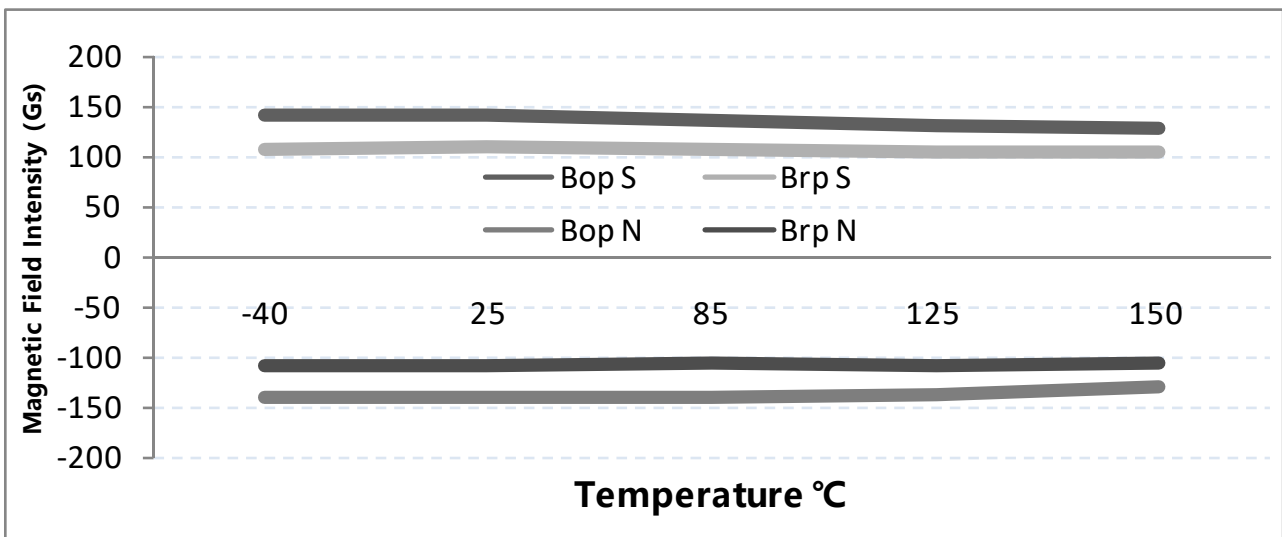

Figure.6 Magnetic Characteristics vs. Temperature (BOP & BRP)

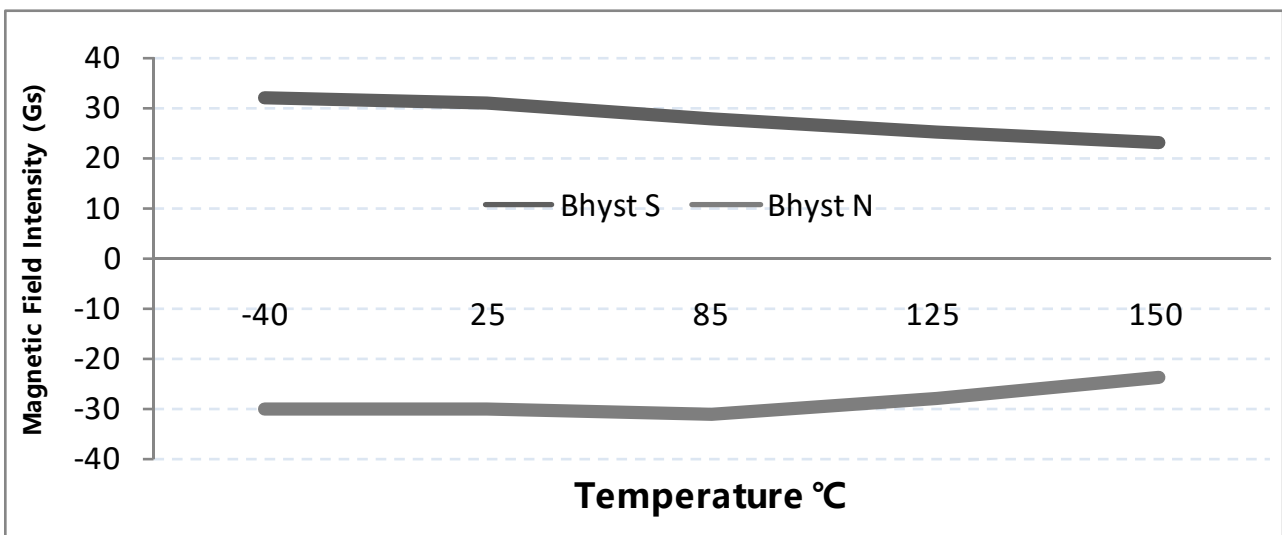

Figure.7 Magnetic Characteristics vs. Temperature (BHYST)

10.6 Typical Output Waveform

MT3303A-EN as example

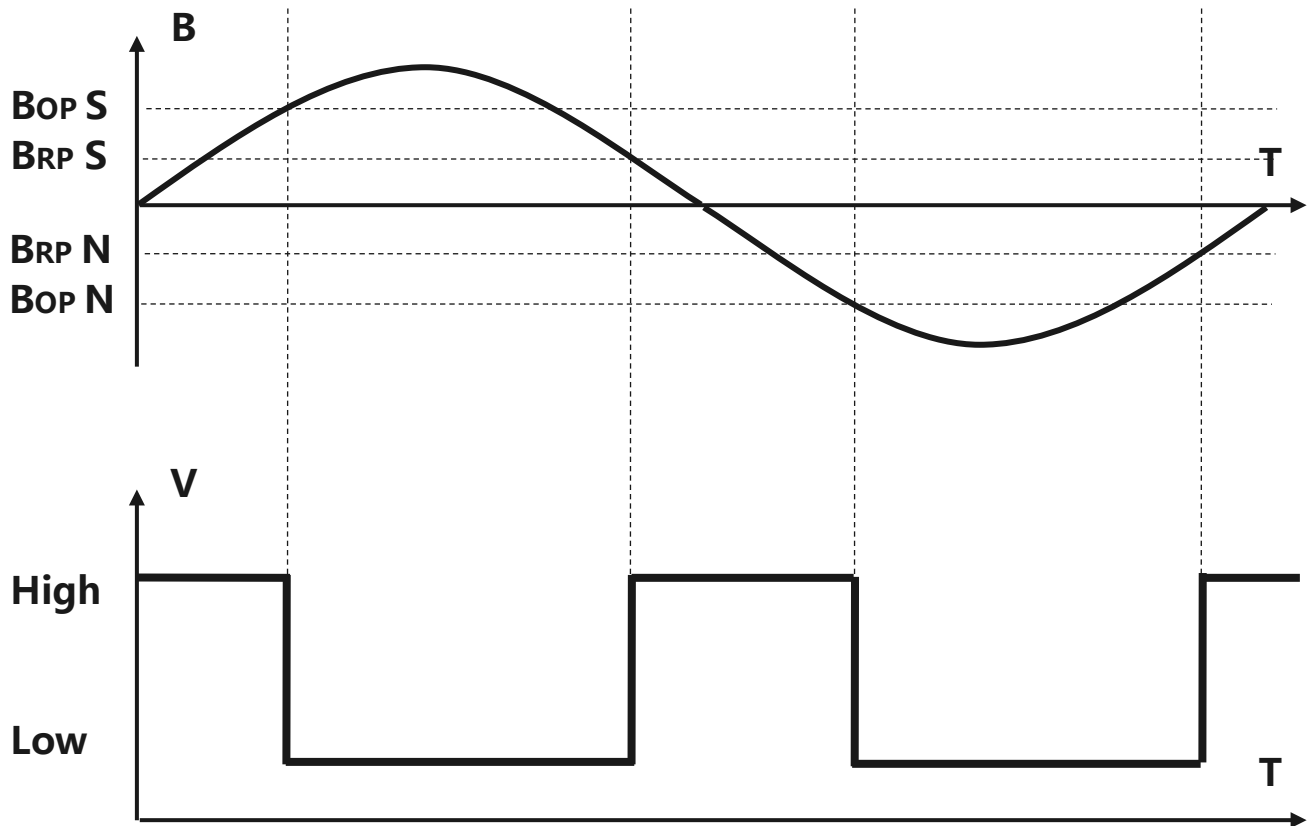

Figure.8 Digital Output vs. Magnetic Flux Density

11 Typical Application Circuit

MT3303AT-EN as example

Note: Recommended value for R_L is 1KOhms to 10KOhms

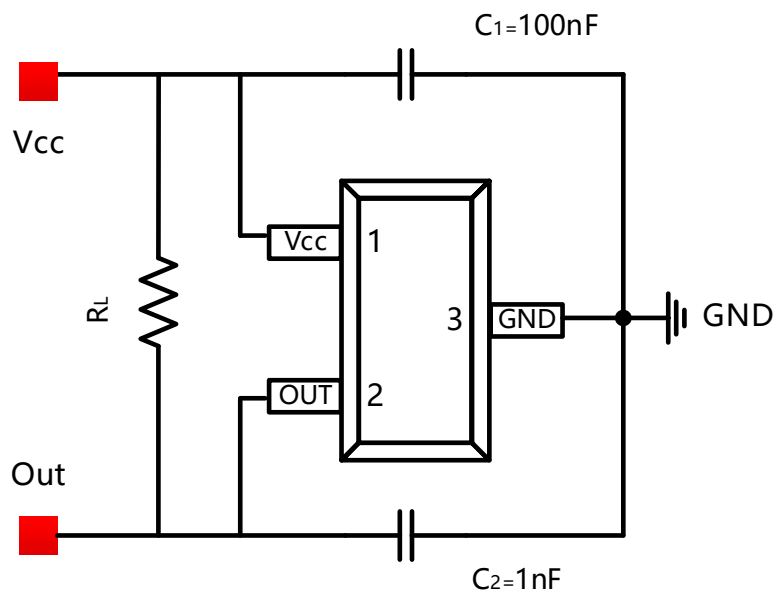

Figure.9 Typical Application Circuit

12 Package Material Information (For Reference Only – Not for Tooling Use)

12.1 SOT-23 Package Information

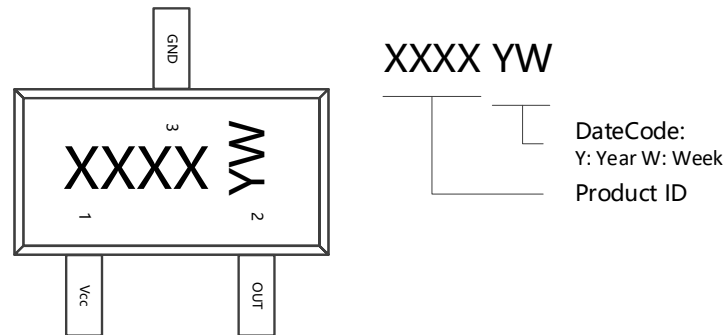

Figure.10 SOT-23 Chip Marking Spec

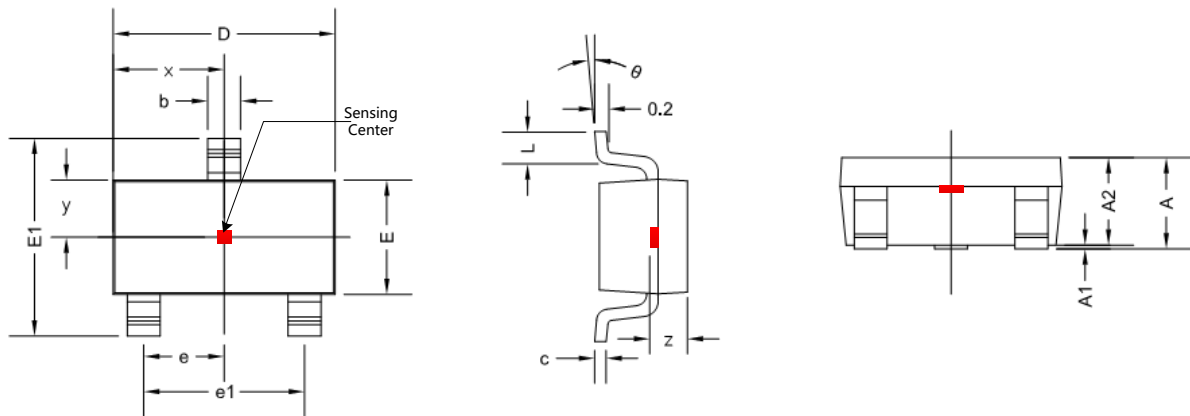

Figure.11 SOT-23 Package Drawing

| Symbol | Dimensions in Millimeters | | Dimensions in Inches | |
|----------|---------------------------|-------|----------------------|-------|
| | Min | Max | Min | Max |
| A | 1.050 | 1.300 | 0.041 | 0.051 |
| A1 | 0.000 | 0.150 | 0.000 | 0.006 |
| A2 | 1.000 | 1.200 | 0.039 | 0.047 |
| b | 0.300 | 0.500 | 0.012 | 0.020 |
| c | 0.080 | 0.220 | 0.003 | 0.009 |
| D | 2.800 | 3.020 | 0.110 | 0.119 |
| E | 1.500 | 1.700 | 0.059 | 0.067 |
| E1 | 2.600 | 3.000 | 0.102 | 0.118 |
| e | 0.950 TYP | | 0.037 TYP | |
| e1 | 1.800 | 2.000 | 0.071 | 0.079 |
| L | 0.300 | 0.600 | 0.012 | 0.024 |
| θ | 0 ° | 8 ° | 0 ° | 8 ° |
| x | 1.460 TYP | | 0.057 TYP | |
| y | 0.800 TYP | | 0.032 TYP | |
| z | 0.600 TYP | | 0.024 TYP | |

12.2 Flat TO-92 Package Information

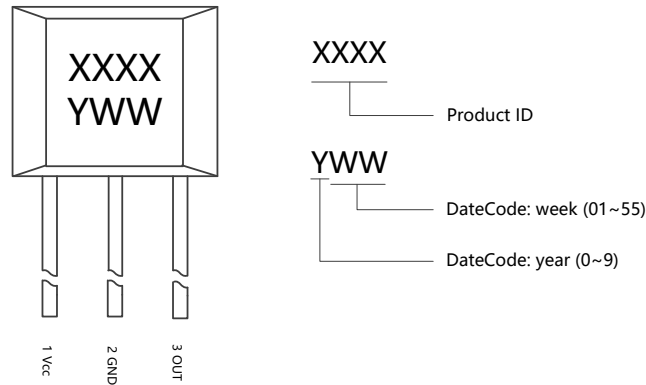

Figure.12 Flat TO-92 Chip Marking Spec

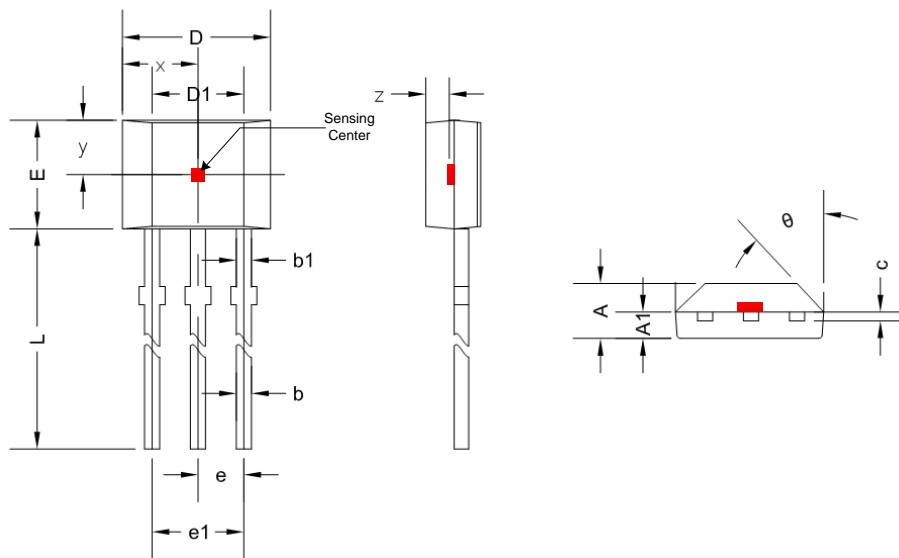

Figure.13 Flat TO-92 Package Drawing

| Symbol | Dimensions in Millimeters | | Dimensions in Inches | |
|--------|---------------------------|--------|----------------------|-------|
| | Min | Max | Min | Max |
| A | 1.420 | 1.620 | 0.056 | 0.064 |
| A1 | 0.660 | 0.910 | 0.026 | 0.036 |
| b | 0.330 | 0.560 | 0.013 | 0.022 |
| b1 | 0.400 | 0.510 | 0.016 | 0.020 |
| c | 0.330 | 0.510 | 0.013 | 0.020 |
| D | 3.900 | 4.200 | 0.154 | 0.165 |
| D1 | 2.280 | 2.680 | 0.090 | 0.106 |
| E | 2.900 | 3.280 | 0.114 | 0.128 |
| e | 1.270 TYP | | 0.050 TYP | |
| e1 | 2.440 | 2.640 | 0.096 | 0.104 |
| L | 13.500 | 16.200 | 0.531 | 0.638 |
| θ | 45 ° TYP | | 45 ° TYP | |
| x | 2.025 TYP | | 0.080 TYP | |
| y | 1.545 TYP | | 0.061 TYP | |
| z | 0.500 TYP | | 0.020 TYP | |

13 Copy Rights and Disclaimer

1. This document may not be reproduced or duplicated, in any form, in whole or in part without prior written consent of MagnTek . Copyrights © 2019, MagnTek Incorporated.
2. MagnTek reserves the right to make changes to the information published in this document at anytime without notice.
3. MagnTek' s products are limited for use in normal commercial applications. MagnTek' s products are not to be used in any device or system, including but not limited to medical life support equipment and system.

For the latest version of this document, please visit our website: www.magntek.com.cn